

### For co-simulation with MATLAB / SIMULINK\*

The SimCoupler Module is an add-on module to the PSIM software. It provides interface between PSIM and Matlab/Simulink for co-simulation, so that part of a system can be implemented and simulated in PSIM and the rest in Matlab/Simulink.

Matlab/Simulink is widely used in control system simulation. However, it is awkward and cumbersome to simulate electric circuits, especially power electronics circuits, in Matlab/Simulink. The SimCoupler Module enables Matlab/Simulink users to represent and simulate power circuits in their original circuit form, thus greatly shortening the time to set up and simulate a system which includes electric circuits and motor drives. Also, Matlab/Simulink users will be able to make use of a variety of built-in electric machine models in PSIM through the Motor Drive Module.

At the same time, the SimCoupler Module allows power electronics researchers and engineers to simulate control in the Matlab/Simulink environment, and the SimCoupler Module further enhances PSIM's control simulation capability by providing access to numerous Simulink toolboxes for various applications. For example, it is now possible to achieve automatic code generation. First, one will perform the co-simulation by simulating the power circuit in PSIM, and the control in Matlab/Simulink. Then use Simulink toolboxes and supporting resources to generate production quality code automatically for a target platform.

The SimCoupler Module is straightforward and easy to use with minimum input from users. The interface is done through link nodes in PSIM, and the SimCoupler model block in Simulink.

As an example, the figure on the right shows a permanent-magnet synchronous motor (PMSM) drive system with the power converter and motor implemented in PSIM, and the control implemented in Simulink. In PSIM, three stator currents and motor mechanical speed are connected to output link nodes to pass the values to Simulink, and in return, three modulation signals are connected to input link nodes to receive values back from Simulink. In Simulink, the SimCoupler model block (highlighted), which represents the PSIM calculation, connects to the rest of the system through input/output ports. With the SimCoupler Module, one can make full use of PSIM's capability in power simulation and Matlab/Simulink's capability in control simulation in a complementary way.

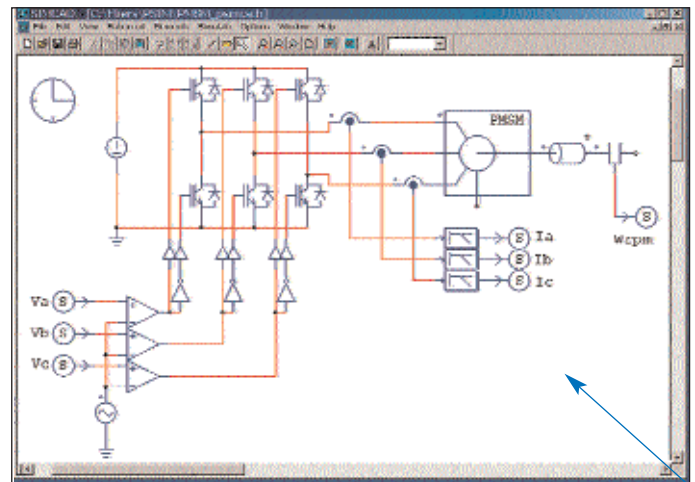

*PMSM drive system with the power circuit implemented in PSIM*

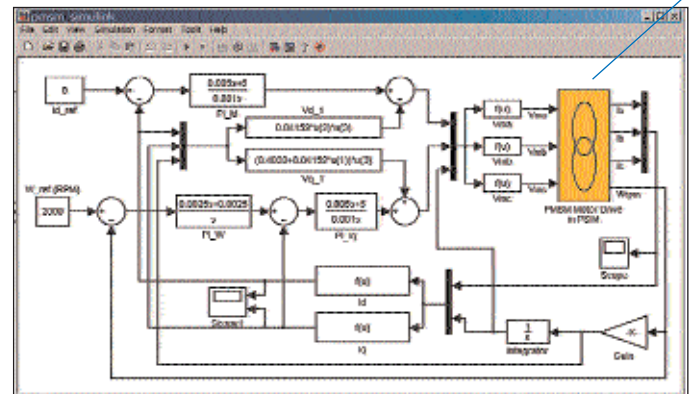

*PMSM drive system with control implemented in Simulink*

### Key Features :

- Easy to use
- Minimum user input
- Fast simulation
- Waveform display in both PSIM and Simulink

\*Matlab and Simulink are registered trademarks of the MathWorks, Inc.