

The digital Control Module is an add-on module to the PSIM software. It is provided to analyze control systems in z-domain. It can be used to simulate the performance of digital control loops, study digital filters, and evaluate various effects in digital control, such as truncation errors, sampling/hold delay, and computational delay. This module is ideally suited to simulate digital control schemes for microprocessors or DSP implementation, and to perform digital signal processing.

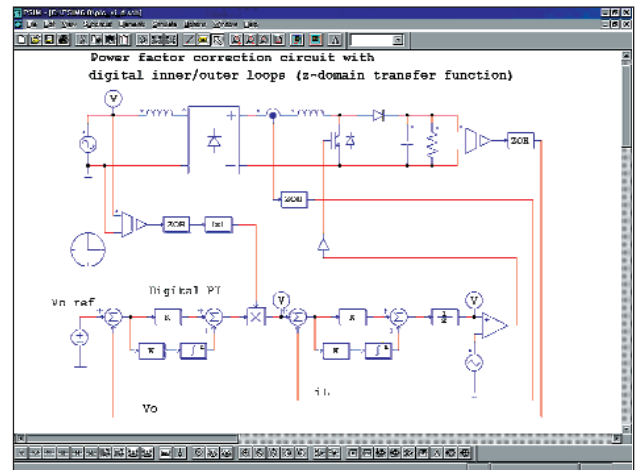

Power factor correction circuit

The Digital Control Module contains the following elements:

- Zero-order hold
- Unit delay
- z-domain transfer function block
- General digital filters
- FIR digital filters
- Discrete integrator
- Resettable discrete integrator
- Discrete differentiator
- Quantization block
- Circular buffer
- Convolution block
- Memory read block
- Vector array
- Stack element

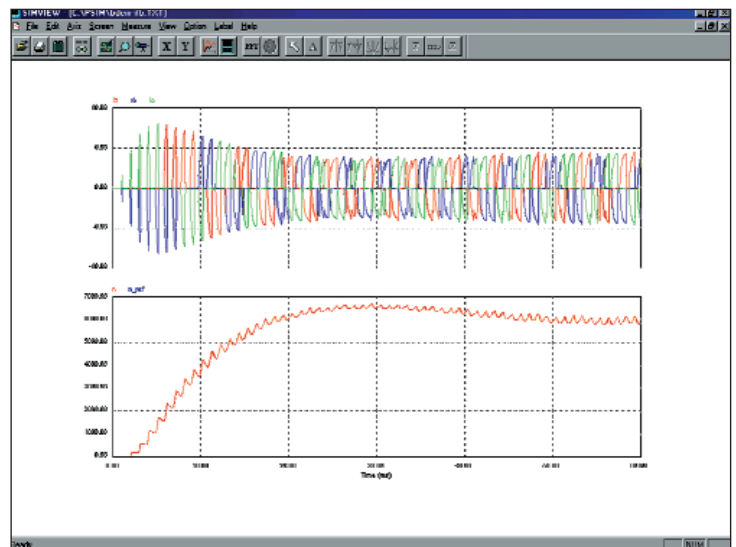

Input voltage and current waveforms

Key Features :

- Easy to use
- Quick and convenient construction of any control circuits
- Common-used control elements