

PSIM can be used for analysis and design of power converters and control systems for a wide variety of applications, including (but not limited to) switchmode power supplies, ac/dc rectifiers, single-phase and three-phase inverters and UPS systems, battery chargers, power factor correction, active filters, reactive power compensators, grid-link operations, and adjustable speed drive systems.

The basic PSIM package consists of three programs: PSIM Schematics, PSIM Simulator, and waveform display program SIMVIEW.

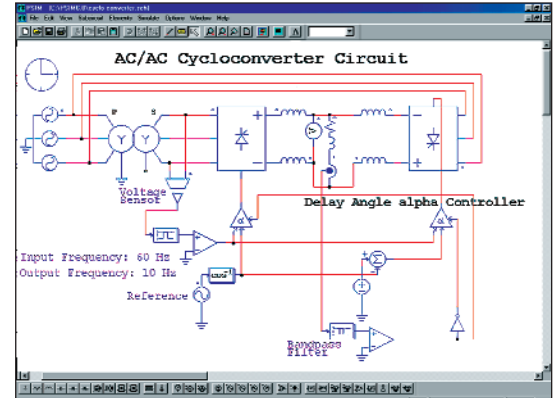

*circuit in PSIM schematics*

PSIM Schematics includes a comprehensive library of electrical engineering items :

- **Power circuits : RLC branches, switches, transformers**
- **Control circuits : filters, function blocks, logic elements, common-used elements (PI Block, Multiplexer, Operational Amplifier...)**
- **Sources : voltage, current, time**
- **Others elements : switch controllers, sensors, probes, non linear elements ...**

and has a lot of sample circuits :

- **Inverters**
- **DC Switchmode Power Supplies**
- **PWM IC Models**
- **Rectifiers and Cycloconverters**
- **PFC, Active Filters, Control Loops and much more**
- **Zero-Voltage-Switching (ZVS) and Zero-Current-Switching (ZCS) Circuits**

In addition, three add-on modules are provided for PSIM: Motor Drive Module for motor drives, Digital Control Module for discrete systems and digital control and SimCoupler Module for co-simulation with Matlab/Simulink.

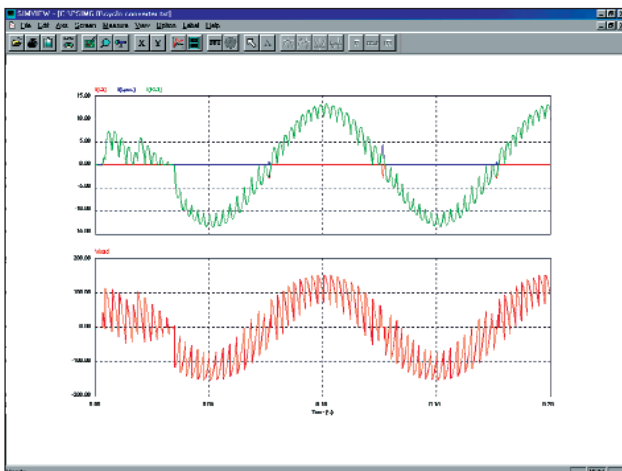

*Waveform in Simview program*

### Key Features :

- **Simple to use**
- **Fast simulation**
- **Flexible control representation**
- **Built-in modules**
- **Link to external C code, C-script block**
- **Add-on modules**
- **AC Sweep (frequency response analysis)**
- **Parameter sweep**
- **Runtime waveform display**